

SANAT PERSIAN MABN A

PVC FABRIC DOOR SYSTEMS

SAVE MONEY
TIME
ENVIRONMENT

SPEED FLEX[®] COLD ROOM DOORS



Cold saver fold up doors are designed to meet expectation of clients for high level insulation for areas like freezer/ chiller rooms & cold storages. Mainly losing of energy is occurred during door operations. Conventional sliding cold room doors are slow in operational speed, obstructs the forklift traffic resulting high energy consumptions. Cold saver door with high speed operation and specially designed for maintaining ambient environment between chilled and freezer area.

7/24 operations

Strong and flexible design of cold saver high speed door can be operated 24x7 specially chosen high resistance fabric and gearbox system are designed for continuous operation.

Excellent sealing

Special designed curtain is filled with high density polystyrene materials. (U value – 0.035W/ (m.k).) curtain reflects the heat radiations from surface . And hence cold saver doors can be utilized from -1 0C down to -30 0C . Side guide has isolation rubber and guide is designed to avoid heat bridge . Cold saver has soft edge system specially made from pot to increase isolation.

Save money and time

Cold server doors reduce energy consumptions more than 20% for air conditioned area. System regulated forklift traffic also save time during operation.

Low maintenance

Cold saver doors doesn't require any special maintenance.

Application

For industries that require isolation, flexibility , performance, uptime and high traffic areas roll up door is a feasible solution.

Maximum Dimensions

*comparison is made between conventional Manuel sliding cold room door at high traffic conditions.

Structure

Structure is made from high straight extruded Aluminum (Alloy 6063 –T6) fixed with bolt & only top cover is made by galvanized steel sheets. All side guides and bottom frames are manufactured to avoid welding . Gap and rust. Stainless steel AISI (304/306) or normal steel structure can be manufactured for special area.

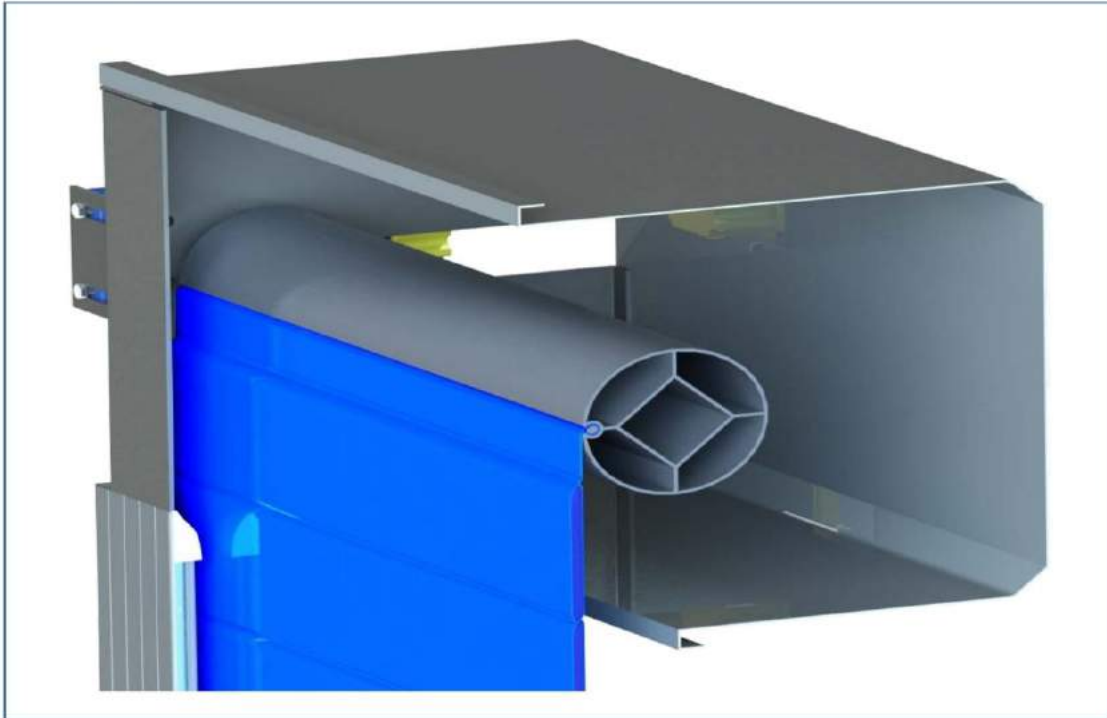

Insulation data

We specially design the door to avoid heat bridge and maximum isolations.

Our patent pending design especially decreases thermal transmittance . Curtain Thermal insulation: $U= 0.70 \text{ W/sq-mt.k}$ (BS EN ISO 6946) sound attenuation :14dB A

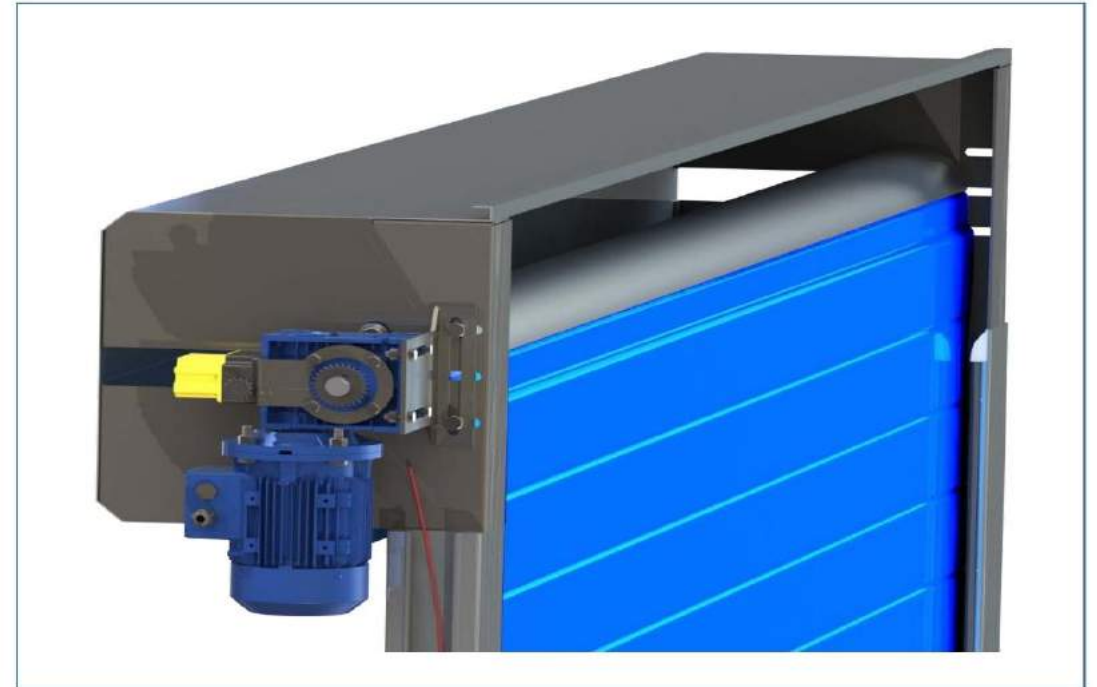

Fabric

fabric has long life and it has very high resistance against uv radiation , VALMEX POLYMAR industrial fire resist 900 gr/m2 1-2 mm 1100 Dtx B 6000 panama SIO – LINE +DIN EN ISO 2286 – 2 CE . Tensile straight 4300/4000 N /50 mm DIN 53354. tear strength 500/500 DIN 53363

Color

wide range of fabric colors are available like RAL 9002-9006-1001-3001-5007-6001-7071.

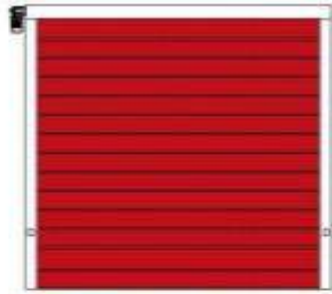

Red - Ral 3020

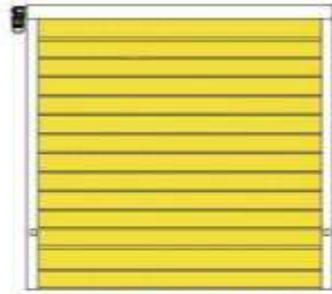

Yellow - Ral 1018

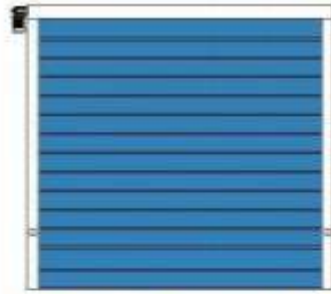

Light blue - Ral 5012



Blue - Ral 5010

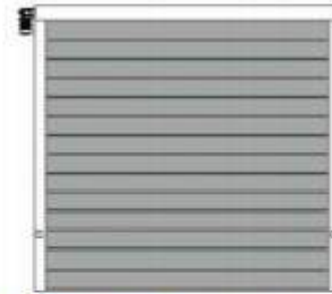

Metalic grey - Ral 9006

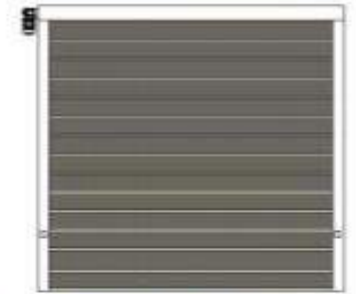

Grey - Ral 7039

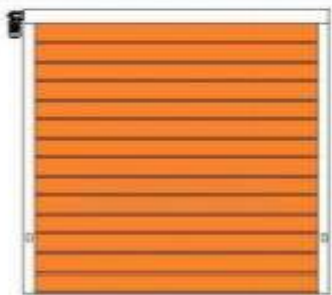

Orange - Ral 2003



White - Ral 9010



Beige - Ral 1013

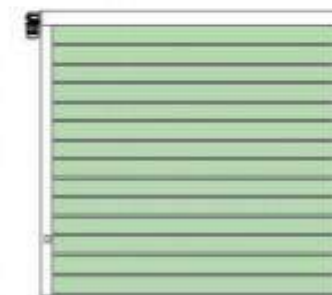

Light green - Ral 6019

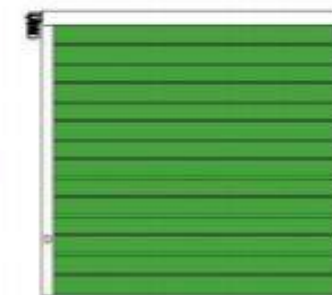

Green - Ral 6018

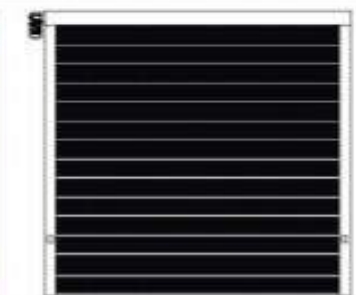

Black - Ral 9005



Isolation material

Extruded polystyrene foam (XPS) consists of closed cells, offers improved surface roughness and higher stiffness and reduced thermal conductivity. The density range is about 28-45 kg/m³. Thermal conductivity varies between 0.029 and 0.039 W/(m.K).

Curtain thickness 40 mm U value (overall heat transfer coefficient) <1.5 W/m².K sound attenuation 18 dB A. Aluminum side rail has rubber sealant for extra isolation.



Interior Heating System

Heating system is used for special condition between Freezer and ambient environment or high level humid environment . In cold room warehouse Doors icing guide, motor and floor are major problems , cold saver high speed door has internal heating system called Deviflex DTIP -8 and DTIP- 10 heating cables which are used in froing of guide, rubber and fabric voltage 230 V AC Effect 8W/m & 10W/m Diameter) 7.4 mm , cold tail 2.5 m, 3 ×1.5 mm² conductor . Insulation XLPE (POLYETHYLENE) sheath insulation pvc 90°C Max. Temperature 65 c

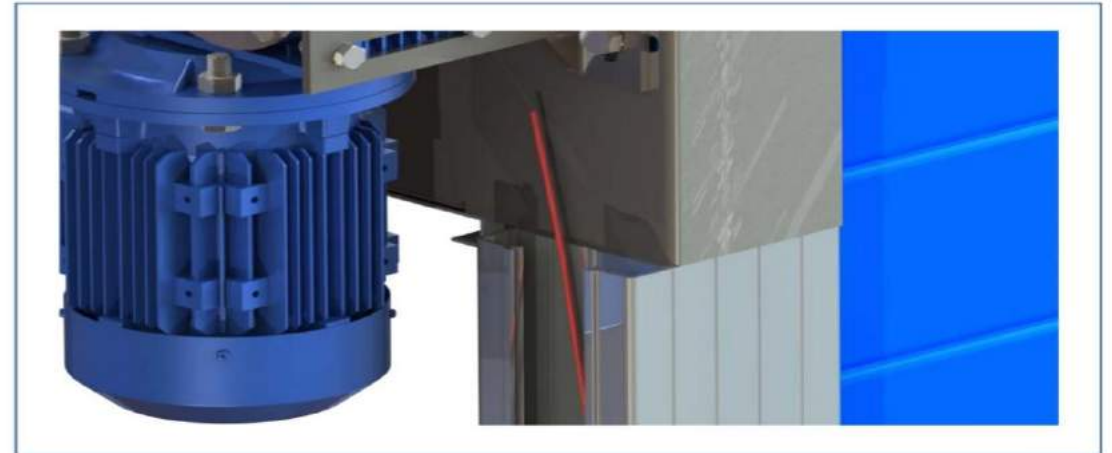

Fire Resistance

Fire resistance of the fabric is suitable for any fire safety regulations. Relative Standard is DIN 4102-B1. These materials are tough to ignite. They include materials such as wood treated with a fire retardant and rigid foam plastics. A fire must extinguish itself when the source of the fire is removed. Isolation materials between fabrics –XPS- has weakness against to fire ignition barrier in accordance with section R314 www.spm-co.com

Motor and Gearbox

Speed

Cold saver High speed Doors can be operated at a standard 1.2 mt/sec (EN12453) and speed range can be designed upto 150 cm/sec.

Equipment

Safety photo cell beam , thermic resistance , soft bottom edge , emergency button warning light and buzzer is supplied standard equipment optionally Bottom safety edge and pneumatic safety edge internal heater system is available.

Safety

All the doors are manufactured according to CE Standard – industrial, commercial product standard – Applicable Directives 89/106/EC-99/93/E Applicable standards:- En 13241-1:2003 +A1:2011-EN 12978:2008.

Motor power from 1HP upto 4HP, operations voltage 380-440 v 3phase 50-60 Hz depending upon dimensions of the doors. 3 phase operation voltage is required for continuous industrial operations. Gearbox is chosen for special high torque worm hole design gearbox. All materials are manufactured according to CE norm

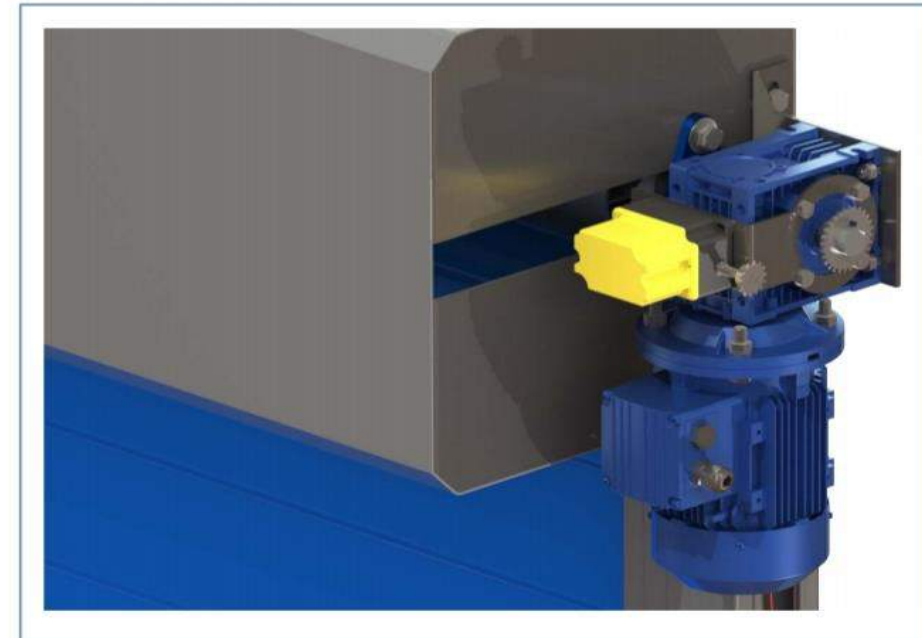



Operations

Control board

Control board is designed according to CE 2006/95 EC and name ics 2 Standard to operate 3 phase motor with rotative switch .Audible and visual warning devices automatically signal for 5 seconds before any door section movement, remain continuously on while the door is in motion and reset immediately after movement stops. IP 65 Box Emergency button Circuit Breakers

Warning light Buzzer , plug in technology .

Options

- frequency converters control board with touch less button
- mono phase operators



Speed flex fabric door is guided up and down in the weather sealing vertical guides attached to structure. Door is controlled by three buttons marked open close and stop . It is controlled by momentary pressure to open and constant pressure to close. (Reverse is available) it can be operated with radar Remote controller, Metallic loop Detectors, pull rope switch as an options.

Loop detectors

Together with inductive loops laid beneath the surface, LC series loop detectors form a universal sensor system for detecting vehicles and forklift. Human traffic is not detectable with loop detectors.

Infrared Radar

Opening impulse sensor for automatic door and industrial doors | Motion sensor for people and objects

Remot Controller

Is a component of an electronic device to operate the device with radio frequency from a long distance (25 mt up to 100 mt)

Manual Operations

In Emergency situations or power is of doors can be operated manually with standard hand crank attached to output shaft of motor.

www.spm-co.com

**SAVE
MONEY
TIME
ENVIRONMENT**

www.spm-co.com

info@spm-co.com



No 401- 4th floor -mehregan buildin-
daneshamoz bolvar- karaj

code:3136973587

fax:982634275220

Tell:982634275121

SANAT PERSIAN MABNA
SPEED FLEX® COLD ROOM DOORS

